



Signaling Technology

A perfect fire alarm system needs perfect planning.

Planning and projecting audible and visual signaling
devices compliant with EN 54-3 and EN 54-23.

Table of contents

Your attention, please!

The planning and projecting of alarm solutions are subject to stringent requirements: they must be standard compliant, but also as effective and as economical as possible. Our aim is to help you to plan with as much certainty as possible.



Audible alarm

How to avoid planning errors.

page 4–5



EN 54-3

The standard that visualises performance.

page 6–7



Planning

Selecting a signaling device with confidence.

page 8–11

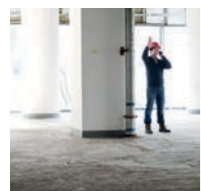

Planning

The risk of incorrect dimensioning.

page 12–13

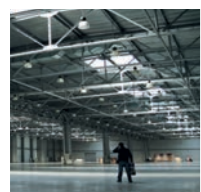

Application

Optimum planning with correct coverage area.

page 14–17



Visual alarm

EN 54-23. An EU standard demands action.

page 18–19



EN 54-23

The standard and its requirements.

page 20–21



EN 54-23

A look at the coverage area.

page 22–23



Planning and application

Most efficient: category O.

page 24–29



Approved product

Planning certainty ex works.

page 30–31

Audible alarm

How to avoid planning errors.

Audible warning signals must be heard without fail by everyone present throughout a given area. To achieve this level of performance, it is necessary to take more than just a single dB value into account – it also requires accurate knowledge of the actual coverage area of the signaling device.



Audible signaling devices and their task.

As an important component of fire alarm and other safety systems, audible signaling devices help to evacuate people from a building as soon as possible after the discovery of a fire or other hazardous situations.

There are several factors which often make this difficult, particularly in areas where there are several operational signals and other loud ambient noise. In these cases, visual alarm equipment is used as well. This is important where people whose ability to hear an alarm is impaired are present, irrespective of whether the impairment is for medical or disease-related reasons, or due to work equipment such as ear protection or media players or has other causes.

As an example, German DIN 33404-3 contains clear provisions for alarm tones that will make the audible alarm more easily heard. Furthermore, DIN VDE 0833-2 stipulates the minimum difference to the ambient sound level throughout the area for which the alarm system is being planned and the minimum sound pressure level for certain situations.

Similar standards are already existing or under development also in other countries.

The planning challenge.

Consideration of the coverage area reached by the signaling device is as crucial to standard compliant planning as determining the minimum dB value. That is, consideration of the space defined individually by the angle of radiation characteristic of a signaling device in conjunction with the ambient noise.

Data sheets from manufacturers or product suppliers often do not contain all the information required which is frequently only found in the relevant approval documents. It is advisable to request these documents from the manufacturer because they provide information about the effective performance and therefore the cost efficiency of a device.

This brochure is intended to help fire alarm system suppliers, installers and planners to deal with the challenges of standard compliant planning with as much reliability as possible.



EN 54-3

The standard that visualises performance.

Standard compliant signaling devices are essential for the reliable planning of alarm solution. As well as knowing the important value: the individual radiation characteristics of the signaling device. EN 54-3 makes this value visible.

Because every angle is important: EN 54-3.

The European standard EN 54-3 describes the requirements, tests and performance features of audible signaling devices which are intended to convey a warning signal issued by a fire alarm system to people in or near to a building.

As well as general equipment requirements, the coverage area of audible devices must fulfil special demands which must be taken into account separately for each certified tone.

The horizontal and the vertical angles of the radiation characteristic of the signaling devices must be tested and defined for each tone.

Only this reveals the rating crucial for reliable planning and projecting: the different performance

characteristics of the signaling device depending on the angle range.

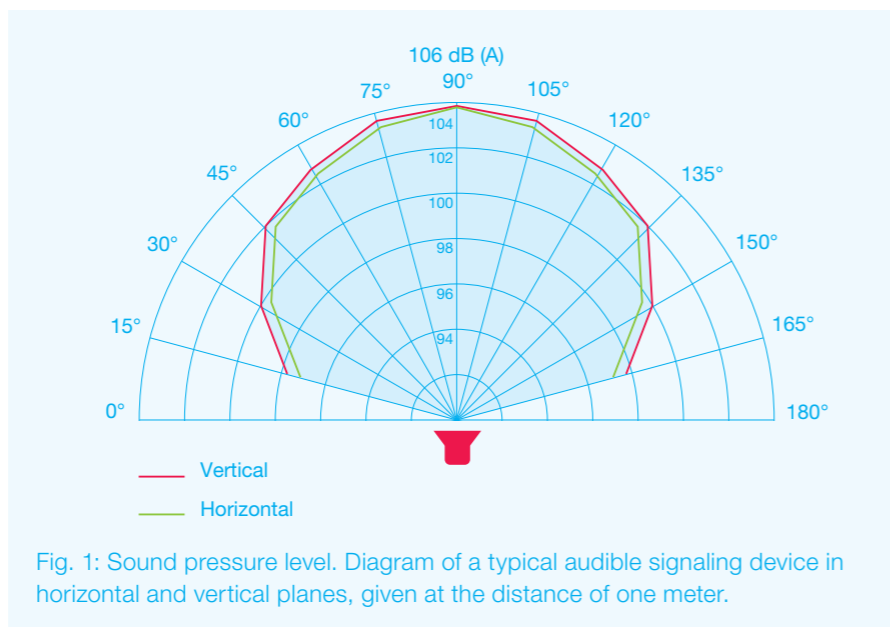

DIN VDE 0833-2 and DIN 14675.

Fundamentally, the transmission paths of audible signaling devices must be designed and installed in accordance with the Specimen Wiring Systems Directive. As well as defining the concept and the documentation requirements with the reference to DIN VDE 0833-1/2, DIN 14675 defines the system-specific requirements.

DIN VDE 0833-2 sets out the following requirements for the relevant audible signal:

- Sounders must always exceed the level of ambient noise by 10 dB.
- The signal issued by the audible signaling device must comply with the emergency signal specifications

stipulated in DIN 33404-3.

DIN 33404-3.

- In areas where people rest or sleep, the sound of the signaling devices must be at least 75 dB (A) at the sleepers' ear-level.

DIN 33404-3 "Danger signals for workplaces" defines the German emergency signal, amongst other things.

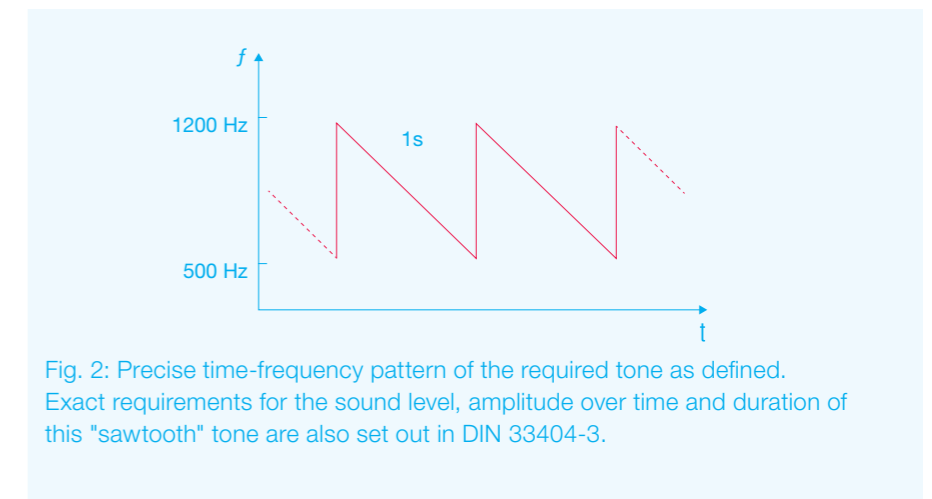

Planning

Selecting a signaling device with confidence.

Many factors influence the choice of the optimum signaling device: technical characteristics such as the radiation characteristic of the signaling device with the signal tone, its structural properties and the ambient sound pressure level.



Environmental conditions.

The necessity to consider each location individually leads in exceptional cases to on-site tests which are carried out in advance. The results thus obtained provide the basis for standard compliant planning. However, it is not always possible to carry out these tests; for example, the building might still be under construction.

In this case, the appropriate ambient noise must be defined to form the basis for standard compliant planning and configuration. The information required can be obtained from the emission values given for machinery and equipment which are often the major sources of noise in an industrial environment.

Initial indications of the usual level

of ambient noise can be obtained from the following table of reference values if no other information or measurement values are available.

Category	Group	Part / Remarks	Ambient sound pressure level in dB (A)*
Trade/Distribution	Logistics	High-bay rack with forklift	60
Trade/Distribution	Logistics	Dispatch/loading and unloading	65
Industry	Automotive	Press	90–110
Industry	Automotive	Automation area	80
Industry	Automotive	Warehouse	70
Industry	Steel	Production	85–110
Industry	Steel	Warehouse	73
Industry	Steel	Logistics	75
Industry	Logistics	High-bay rack with forklift	70
Industry	Logistics	Cold storage	70
Industry	Logistics	Dispatch/loading and unloading	75
Industry	Textiles	Production/weaving machine	85
Industry	Textiles	Machine run, various	78
Industry	Textiles	Processing technology	78
Industry	Chemical industry	Outdoor loading	80

Category	Group	Part/Remarks	Ambient sound pressure level in dB (A)*
Industry	Chemical industry	Warehouse	73
Industry	Wood	Assembly	80
Industry	Wood	Packaging/picking	80
Industry	Wood	Dispatch	75
Industry	Plastic	Loading	75
Industry	Plastic	Production	85–88
Industry	Animal feed	Production	70–75
Industry	Animal feed	Filling	70
Industry	Mechanical engineering	Production	65–75
Industry	Mechanical engineering	Logistics/loading	70
Public	Station	Rails	85
Public	Station	Transport / access for people	70
Public	Airport	Waiting hall	65–70
Public	Airport	Aircraft handling, outdoor	80–90
Public	School	Classroom	65
Public	School	Lecture theatre	75–80
Public	University	Lecture theatre	70–80
Public	University	Seminar room, small	65
Public	University	Seminar room, large	70
Public	University	Library	60
Public	Office	Individual offices	55
Public	Office	Open-plan office	65–70
Public	Office	Call center	75–80
Public	Office	Administration building	60

Technical features.

Planning errors often arise with the assumption that every audible signaling device is a spherical emitter with a signal emitted with even intensity in a ball shape. In order to approach the matter as safely as possible, it is necessary to take into account specific technical features of the sounder.

- Precise sound pressure level. As the volume of a sounder is not identical in every one of the tones implemented, the sound pressure level of the tones used later should be used as a basis for planning.

**These are reference values. It is quite possible that other ambient sound pressure levels apply.*



- Precise radiation characteristic. This is important because each sounder achieves different sound pressure levels depending on the angle of the emission to the source of the noise. These levels are highest in front of the device (90°) and recede significantly at the sides (0°/180°) (see fig. 3).

The precise sound pressure levels and the associated radiation characteristic are determined when the devices are approved and should be requested from the manufacturer. Ensure that the device is certified for the tone required. In Germany this is referred to as the DIN tone. Otherwise the standards do not permit use of the device.

From the radiation characteristics to the coverage area.

Accurate planning and configuration also take account of the coverage area of a device. The graphic compares the coverage area of two signaling devices in the same commercially available performance class "100 dB sounders" with the DIN tone and under identical ambient noise conditions (see fig. 3).

The coverage area actually achieved by each signaling device has been calculated (blue area) based on the individual radiation characteristic of each sounder. To facilitate planning, the red lines mark the usable coverage area for the space.

Visible effectiveness.

An attenuation of the sound level in 0° and 180° can be seen in almost every sounder. While type A signaling devices exhibit attenuation of 6 dB, there is a reduction of 12 dB on type B signaling devices. This 6 dB difference in output halves the signaling distance. A standard compliant alarm system with type B signaling devices would require multiple devices.

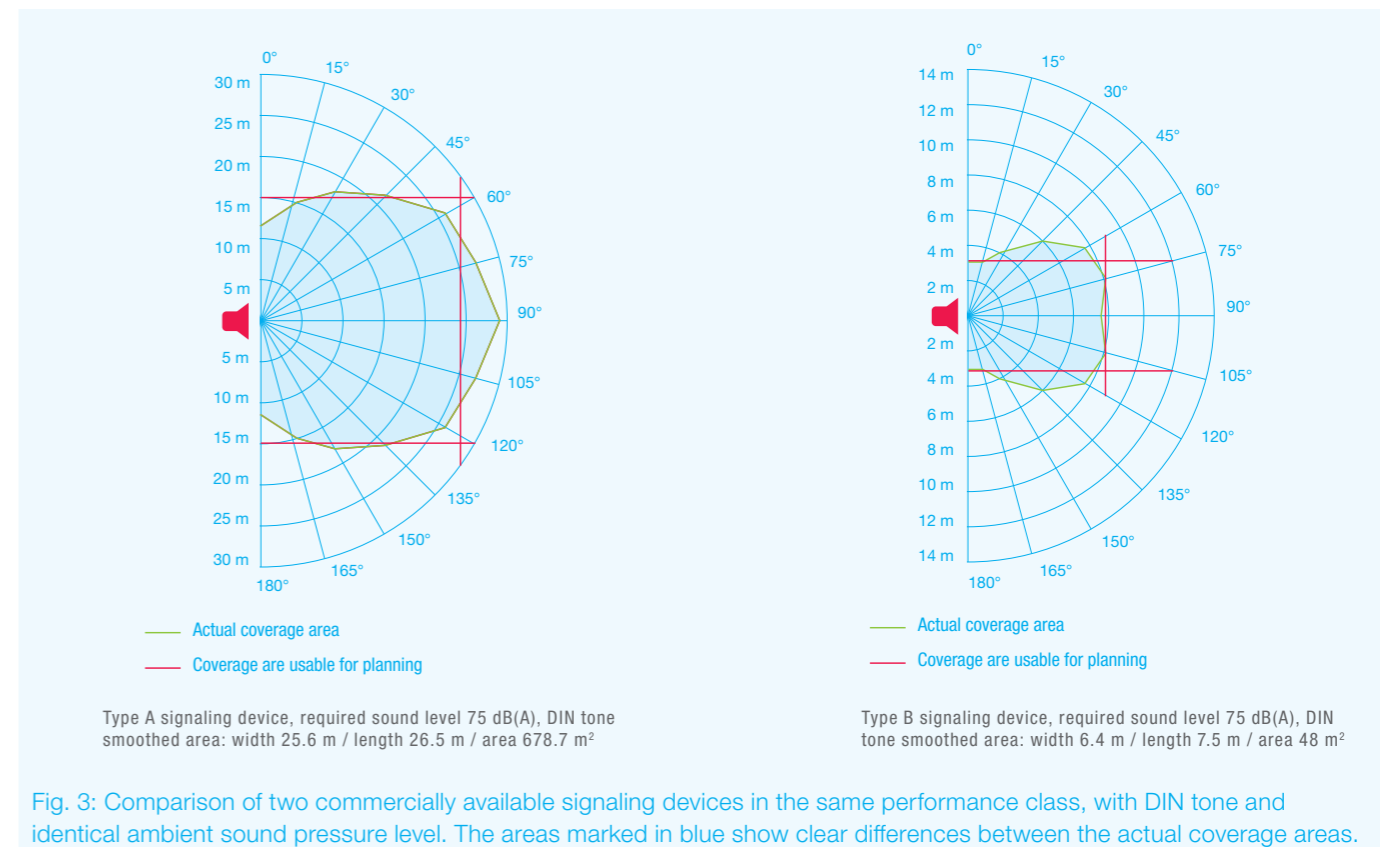

Fig. 3: Comparison of two commercially available signaling devices in the same performance class, with DIN tone and identical ambient sound pressure level. The areas marked in blue show clear differences between the actual coverage areas.

Planning

The risk of incorrect dimensioning.

Each instance of over-dimensioning can result in increased costs and each instance of under-dimensioning in a failure to obtain approval. The causes lie in the use of inaccurate data for planning and configuration. Reliance on experience and on technical data in marketing material can put the commissioning of a system at risk.



Assess sales documentation critically.

Planning on the basis of marketing data sheets and/or experience often results in the configuration of too few signaling devices or the use of insufficiently powerful devices. The reverse can also happen: too many signaling devices, consequently at a higher cost.

For example: some signaling devices are classified as having 103 dB (A) but actual angle measurements in accordance with EN 54-3 show that they offer only 91 dB. If these values are compared in a configuration and the sound propagation diagram is taken into account, it would be necessary to plan for around four times as many signaling devices depending on the situation.

If data checking is inadequate, the fire alarm system might not be approved with the risk that the building might not be put into operation. The least significant consequence would be the installation of either additional or more powerful signaling devices which could impact power supply requirements.

Piezo technology with lower performance.

The technology used to produce the sound is a frequently neglected reason for incorrect dimensioning. Signaling devices based on the piezo effect are often used for fire alarm systems. However their low power consumption only makes them attractive on paper.

If the performance of the devices is taken into account, it can be seen that the piezo technology offers a much smaller coverage area compared to electromagnetic sound generation.

The superior efficiency of electromagnetic sound generation.

The larger coverage area of electromagnetic signaling devices more than compensates for its slightly higher energy consumption. Looked at in relation to each other, it can be seen that electromagnetically generated sound is much more efficient than that generated with piezo electricity.

The attenuation of the high frequency piezo sound generator is much higher than for electromagnetic sound generator.

Application

Optimum planning with correct coverage area.

Each alarm solution must be planned individually. The focus is always on the actual coverage area of the signaling device, which can be used to determine the device requirements. Here is a case study for clarification:



The requirement.

An audible alarm signal for an area of 40 x 32 x 5 m (L x W x H). The ambient noise throughout the area amounts to 80 dB. Therefore at least 90 dB (A) must be achieved throughout the space.

The performance data.

Under the conditions described above, the Pfannenberg PA 10 sounder delivers the performance shown in the values in the table below. The result is the actual coverage area (marked in blue) shown in the polar diagram and the smoothed coverage area (marked in red) which represents area usable for planning.

Ambient noise: 80 dB (A)	Offset to ambient noise: 10 dB						Required sound pressure: 90 dB (A)
	Type: PA 10 / tone: DIN no.1 / horizontal						
Angle	0	15	30	45	60	75	90
Output [dB (A)] @ DIN tone	109	109.5	110.5	112	114.5	117.5	117.5
Distance [m]	9	9	11	13	17	24	24
Angle	105	120	135	150	165	180	
Output [dB (A)] @ DIN tone	117.5	114.5	112	110.5	109.5	109	
Distance [m]	24	17	13	11	9	9	

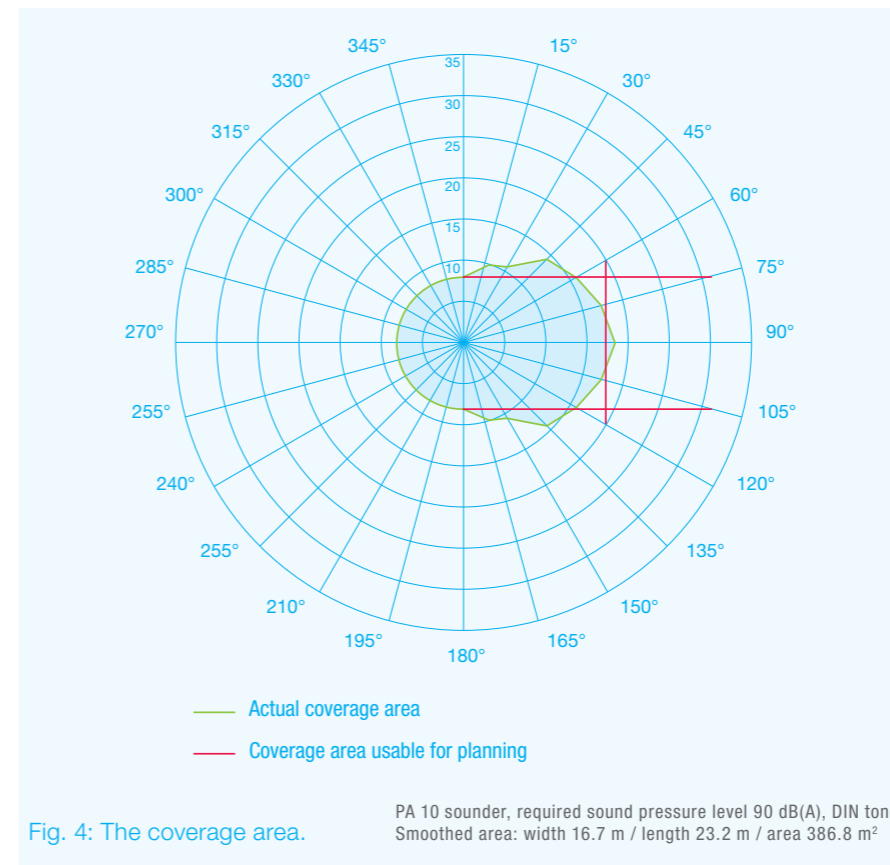

Fig. 4: The coverage area.

Equipment needs.

The actual coverage area with a required sound pressure level of 90 dB (A) gives a smoothed area with a length of 23.2 m and a width of 16.7 m (usable coverage area of the sounder with DIN tone). Four PA 10 devices are required for an audible alarm that will be heard throughout the area which is 40 m in length and 32 m in width.



Cost comparison.

A smaller or a precisely calculated requirement for devices means lower material and installation costs. The comparison shows the cost of a standard compliant signaling system with two signaling devices in the same performance class with DIN tone and identical ambient noise.

	Pfannenberg PA 10	Competitor*
Type		
Cost per unit	240 €	150 €
Units	4	12
Total cost units	960 €	1800 €
Price cable meter	0.3 €	0.3 €
Total length	160	240
Total cost cable	48 €	72 €
Price man per hour	45 €	45 €
Price per minute	0.75 €	0.75 €
Time per unit	12	16
Total time in minutes	48	192
Total cost installing	36 €	144 €
Time cable per meter	2	2
Total time for cabling	320	480
Total cost installing cables	240 €	360 €
Total cost material	1008 €	1827 €
Total cost installing	276 €	504 €
Total cost	1284 €	2376 €

Sample calculations of prices, cost of a 40 x 32 x 5 m (Lx W x H) space.

The result: optimum planning certainty and efficiency.

For reliable and cost-efficient planning of audible signaling devices, it is essential to take individual radiation characteristics into account. Knowledge of the actual coverage area of the signaling devices gives you optimum planning certainty over the whole project phase and guarantees a standard compliant alarm system that meets requirements.

*Commercially available device in the same performance class.

Additional benefits.

As well as determining the optimum number of devices to be installed, the procedure outlined here has other advantages:

- Determines the permissible distances between devices.
- Avoids incorrect dimensioning.
- Cuts the overall costs of the installation.
- Avoids failure to obtain approval.

Let us help you plan a customised audible alarm solution. Please get in touch.



Visual alarm

EN 54-23. An EU standard demands action.

Since the beginning of 2014, certified visual and/or visual-audible signaling devices have been mandatory for fire alarm systems. As a leading company in the area of signaling technology, we help you to plan your projects using certified products with superior efficiency and maximum certainty possible.

Stricter requirements.

The introduction of the EU standard EN 54-23 on January 1, 2014, significantly increased the requirements imposed on visual systems for alarm people. Certified visual and/or visual-audible signaling devices are now mandatory for fire alarm systems. EN 54-23 also stipulates special requirements for light output and light distribution.

Visual alarms must now be provided in many alarm scenarios which previously used only audible signals. The basis for this is the alarm concept based on DIN 14675 and VDE 0833-2. This is becoming increasingly important in addition to the planning of device coverage area.

An urgent need for action.

This means that there is a need not only for information but also for action on the part of everyone and every company entrusted with the planning and installation of fire alarm systems: planners/engineers, experts in fire alarm technology, system integrators and manufacturers of fire alarm control panels, suppliers of electrical installations, construction companies and building management companies in every EU country.

Planning certainty with certified products.

We are the first manufacturer to offer you optimum planning certainty for any building project – with visual signaling devices which are certified in accordance with EN 54-23 and with VdS.

When to use a visual alarm system?

Fundamentally a visual alarm system should be used when the fire protection concept provides for it. Actual application scenarios are:

1. Areas in which ear protection is worn
2. Areas in which audible signals cannot be heard or only to a limited extent
3. Areas in which the hard-of-hearing might be present
4. Building with access for handicapped: audible and visual alarm in accordance with e.g. DIN 18040-1 Equality of Disabled Persons Act

EN 54-23

The standard and its requirements.

The European standard EN 54-23 describes the requirements, tests and performance characteristics for visual signaling devices. They concern the light intensity, the installation position, the type of building and the light colour.



Light intensity.

The light intensity throughout the area covered is required without exception to be 0.4 lm/m².

Installation position.

Visual signaling devices are divided into three licensing categories: ceiling-mounted (category C), wall-mounted (category W) and open installation (category O). In the open category, the coverage area is determined by the installation position.

Building type/environmental class.

Another parameter defines indoor (type A) or outdoor use (type B). The manufacturers should provide information about the performance characteristics of the signaling devices resulting from the individual installation positions.

Light colour.

A white or red flashing light with a flashing frequency of 0.5 to 2.0 Hz is permitted.

Effect of the total system on power consumption.

The points made above can have a significant impact on planning the number of signaling devices required to provide an alert and on their arrangement.

Configurations with a relatively high power consumption for the peripheral devices of fire alarm systems can result; a contributing factor is the number of signaling devices required to achieve the light intensity within the area in which the alert is to be registered. This can make increased demands on the mains network and the power supply to the fire alarm system.

The growing importance of manufacturer specifications.

Within the framework of the conformity declaration in accordance with EN 54-23, manufacturers define the mode of installation with the signaling range for each device within which the stipulated value of 0.4 lm/m² is reached. These details, along with planning and configuration, provide evidence of correct installation.

A functional and visual inspection in conjunction with the relevant fire alarm system concept including the alarm concept compliant with the data provided by the manufacturer for the product must take place on site.

Tenders/list of specifications.

When drawing up tenders and lists of specifications, ensure that as well as the general device requirements, the signaling range used to produce the plans is specified. Otherwise, there will undoubtedly be discrepancies in the coverage of the area in which the alert should be registered. This also applies to audible signaling devices.

EN 54-23

A look at the signaling range.

EN 54-23 defines three different approval categories, imposing specific requirements on ceiling-mounted signaling devices (category C), wall-mounted signaling devices (category W) and on signaling devices which can be positioned as required (category O). Different shapes are defined for the signaling range, depending on the category.



Open installation position (category O).

Neither the shape of the signaling range nor the installation position is stipulated for devices in category O. This means, there are no restrictions on the structure of the signaling range.

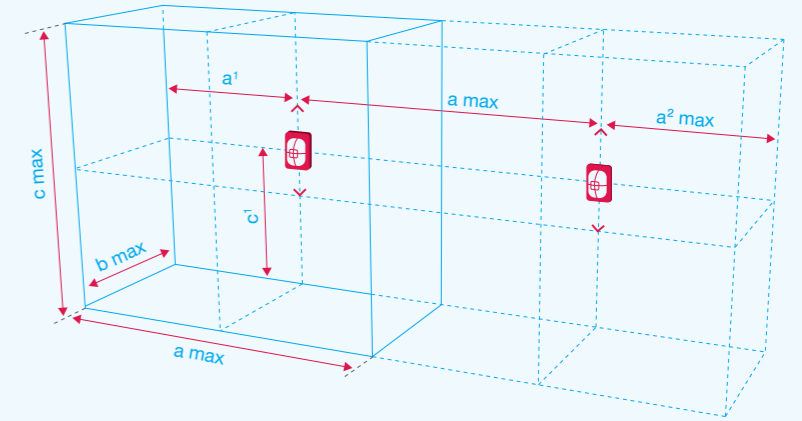

Fig. 8: Wall/pillar-mounted devices.

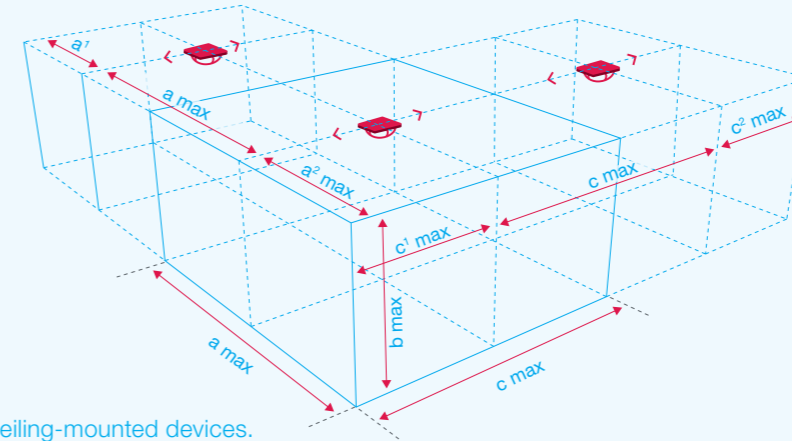

Fig. 7: Ceiling-mounted devices.

Ceiling installation (category C).

Category C devices are described with the code C-x-y. x stands for the maximum height in meters at which the signaling device may be installed. y is the diameter of the signaling range as the EN 54-23 standard specifies a cylindrical signaling range for this category. Furthermore, signaling devices in this category can be classified for use at heights of up to 3, 6 or 9 meters.

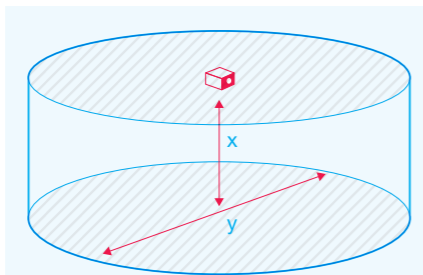

Fig. 5: Signaling range for category C devices.

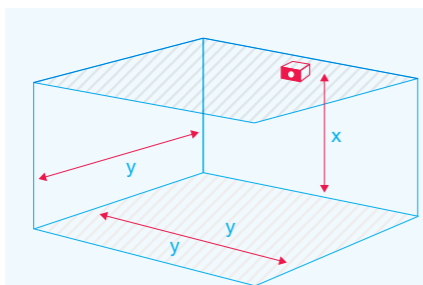

Fig. 6: Signaling range for category W devices.

Wall-mounted devices (category W).

Category W devices are described with the code W-x-y. x is the maximum height in meters at which the signaling device can be fitted; standard EN 54-23 stipulates a minimum installation height of 2.4 m. y defines the surface area of the signaling range which is cuboid in this category.

The requirements of DIN VDE 0833-2 and DIN 14675.

Like those of audible signaling devices, the transmission paths of visual signaling devices must be designed and installed in accordance with the Specimen Wiring Systems Directive. DIN 14675 determines the framework within which the concept and the documentation should be drawn up and also defines the system-specific requirements with a reference to DIN VDE 0833-1 or 2.

Taking the new EU standard into account, DIN VDE 0833-2 sets out the following requirements for the relevant visual signal:

1. Certain audible and visual

signaling devices for internal alarms must be compliant with EN 54-3 and EN 54-23. Any additional signaling devices selected need not comply with the standards described above.

2. If visual signaling devices can be confused with other operational information, they must be labeled "fire alarm".

3. As stipulated in EN 54-23, visual signaling devices are divided into category C for mounting on ceilings, with the designation C-x-y (e.g. C-9-6), W for mounting on walls with the designation W-x-y (e.g. W-6-5) and O with specific manufacturers' information for the signaling range.

4. Visual signaling devices should be installed in a way that the area to be illuminated is completely

covered. If this is not the case, more visual signaling devices should be installed.

5. If it is not possible for people to be present at 2.5 m, the signaling range needs only to reach to this height.

The specifications of the manufacturer as well as the requirements imposed on signaling devices by DIN VDE 0833-2 and DIN 14675 must be considered.

*Requirement not yet made public. The right to make changes is reserved. Version dated October 2015.

Planning and application

Most efficient: category O.

Both EN 54-23 and DIN VDE 0833-2 contain specifications for precise planning of signaling range depending on the approval categories. Here is an example to illustrate the differences resulting from the installation position. It shows that category O signaling devices achieve the highest efficiency.



Sample application of approval categories.

The room used in the example is 20 m long, 8 m wide and 3 m high. The following three devices are compared in the design.

1. The Pfannenberg flashing light PYRA (category O) with a signaling range measuring 11.1 m x 8.4 m x 6.3 m.

2. The same device (assuming approval for ceiling installation), coverage area C-6-10.6. (This device is not available with this specification. The crucial point is the choice of installation category.)

3. A comparable device in category C-3-7.5.

Due to the specified signaling range, the number of devices required is as follows (see fig. 9).

Number of devices required: 2

Number of devices required: 6

Number of devices required: 8

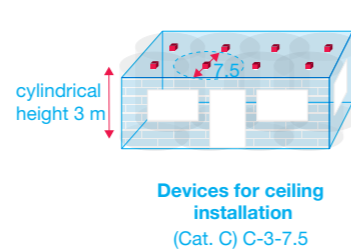
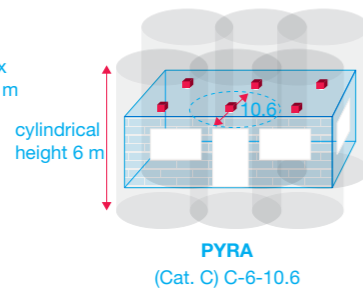
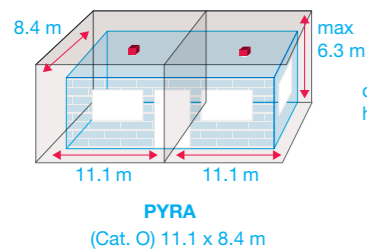

Fig. 9: Number of devices required by approval category. If the ceiling of the room were just 1 cm higher, the third variant could not be used.

	Pfannenberg PY X-S, cat. O	Exemplary PY X-S, cat. C	Device with C-3-7.5
Material			
Type			
Cost per unit	80 €	80 €	55 €
Units	2	6	8
Total cost units	160 €	480 €	440 €
Price cable meter	0.3 €	0.3 €	0,3 €
Total length	160	180	200
Total cost cable	48 €	54 €	60 €
Installing			
Price man per hour	45 €	45 €	45 €
Price per minute	0.75 €	0.75 €	0,75 €
Time per unit	12	12	16
Total time in minutes	24	72	128
Total cost installing	18 €	54 €	96 €
Time cable per meter	2	2	2
Total time for cabling	320	360	400
Total cost installing	240 €	270 €	300 €
Total cost material	208 €	552 €	518 €
Total cost installing	258 €	324 €	396 €
Total cost	466 €	876 €	914 €

Sample calculations of prices, cost of a 20 x 8 x 3 m (L x W x H) space.

Planning and application

Most efficient: category O.

The superior economy of signaling devices in category O can be improved by taking the light colour into account in the planning. We use an example to illustrate how the number of devices can be reduced.

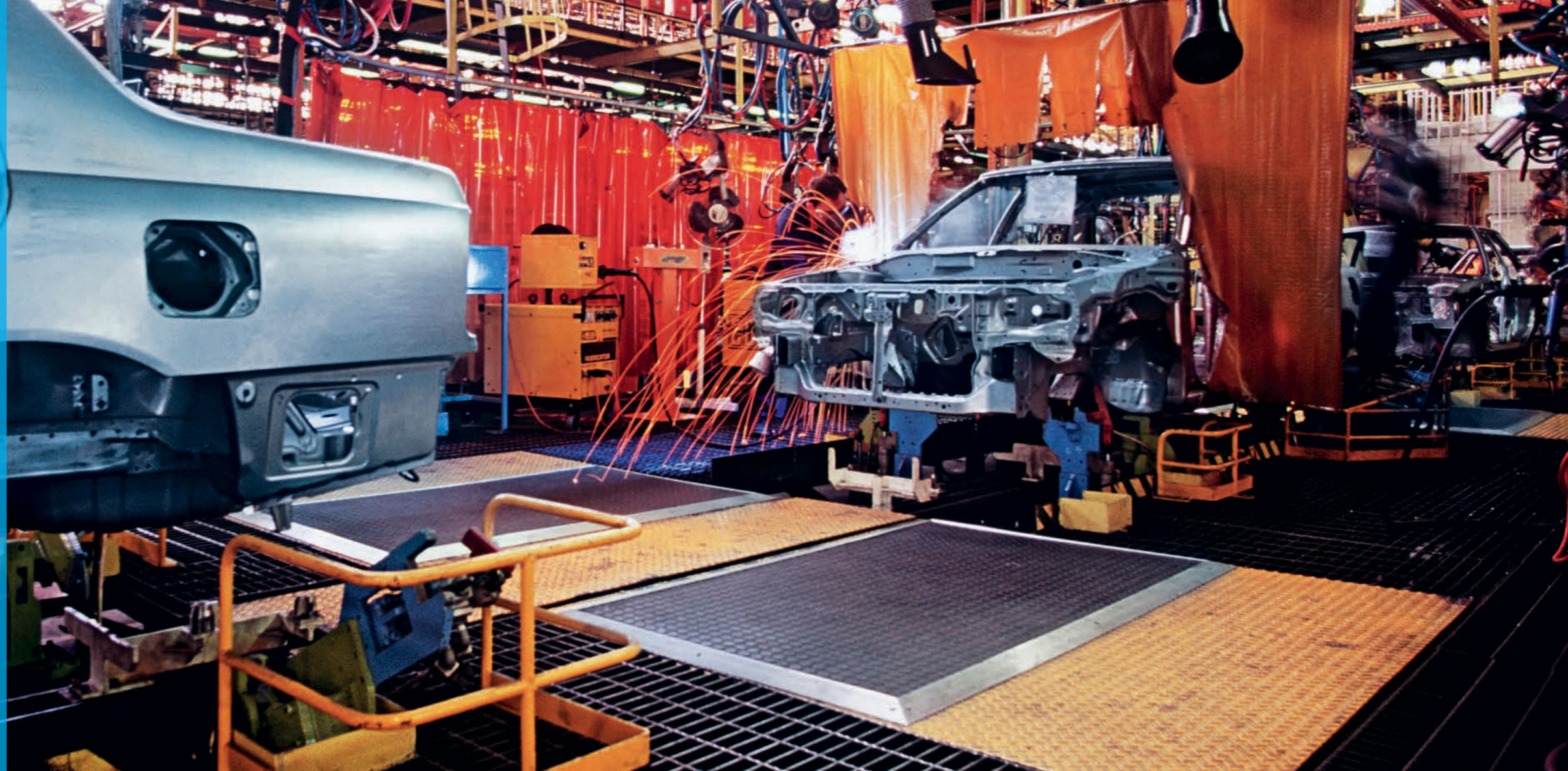

Application example focusing on the light colour.

The space used in the example is 110 m long, 15 m wide and 8 m high. The signal is intended to cover the whole space. These are the devices compared in the planning process.

1. Product A, clear: cat. O, 28 m x 24 m x 13 m (W x L x H)
2. Product B, red: cat. O, 17 m x 16 m x 10 m (W x L x H)

Due to the specified coverage area, the number of visual signaling devices is as follows:

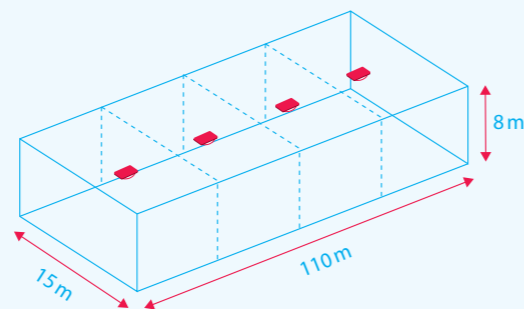

Fig. 10: Just four devices in the light colour "clear" are needed to provide an alert throughout the area specified.

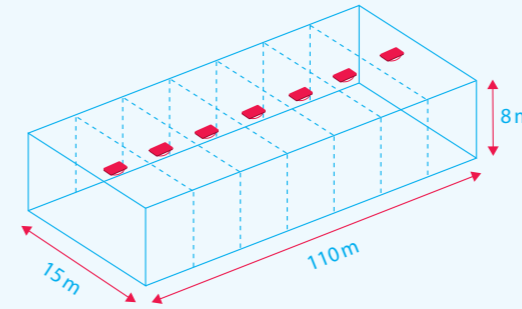

Fig. 11: Seven devices in the light colour "red" are needed to provide an alert throughout the area specified.

Sample calculations of prices, cost of a 110 x 15 x 8 m (L x W x H) space.

	Pfannenberg PY X-M 10, clear PY X-M 10, red	Exemplary PY X-S, cat. C
Material		
Type		
Cost per unit	240 €	240 €
Units	4	7
Total cost units	960 €	1680 €
Price cable meter	0.3 €	0.3 €
Total length	160	240
Total cost cable	48 €	66 €
Installing		
Price man per hour	45 €	45 €
Price per minute	0.75 €	0.75 €
Time per unit	12	12
Total time in minutes	48	84
Total cost installing	36 €	63 €
Time cable per meter	2	2
Total time for cabling	320	440
Total cost installing cable	240 €	330 €
Total cost material	1008 €	1746 €
Total cost installing	276 €	393 €
Total cost	1284 €	2139 €

Planning and application

Most efficient: category O.

Signaling devices in category O are the first choice for visual alarm due to their larger signaling range and their unbeatable economy.



Summary.

1. Category O devices are the most flexible solution.

These signaling devices can be mounted on the ceiling, wall or in other positions, whereas devices in categories C and W can only be mounted in compliance with their classification.

2. Category O devices are the most economical solution.

- Only one signaling device is required for every installation position. This avoids the need to keep similar products in stock.
- There is no limit to the height of the installation – devices designated C-3-y are not approved for use on ceilings of 3.2 m and a device

in category C-6-y has to be used which would be significantly overdimensioned for this application.

- For category C devices, the actual signaling range is initially reduced to a cylindrical shape. In order to apply the shape of a cylinder to a room or to make it possible to design the signaling for a room, the coverage has to be reduced again to the largest possible rectangular shape. This automatically requires the use of a larger number of signaling devices in order to ensure that the signal covers the whole room.

- The rectangular surface area specified for devices in category W results in a reduction of the actual signaling range on the shorter side. The artificially reduced coverage area means that an increased

number of devices is required here as well.

- Category O devices are not subject to any restrictions which makes possible the creation of a maximum signaling range in the form of a freely selectable cuboid (see adjacent graphic).

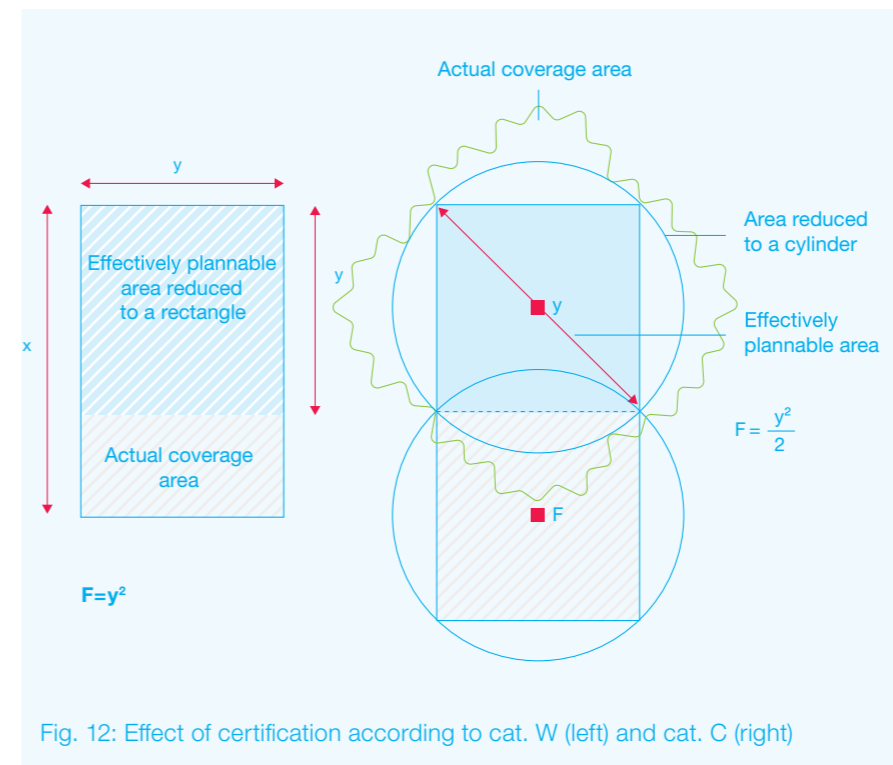

Fig. 12: Effect of certification according to cat. W (left) and cat. C (right)

3. The colour "clear" is the most economical solution for alarm.

The clear flashing light has a broader frequency spectrum than the red. This has two significant advantages:

- The "clear" colour of the alert makes the signal more perceptible.
- The signaling range of devices with a clear flashing light is larger than that of identical devices with a red light.

Let us help you plan a customised visible and visible-audible alarm solution. Please get in touch.

Approved product

Planning certainty ex works.

Our certified signaling devices guarantee that you will have standard compliant planning certainty for audible, visual and visual-audible alarm solutions. And they have even more to offer: superior performance and economy.

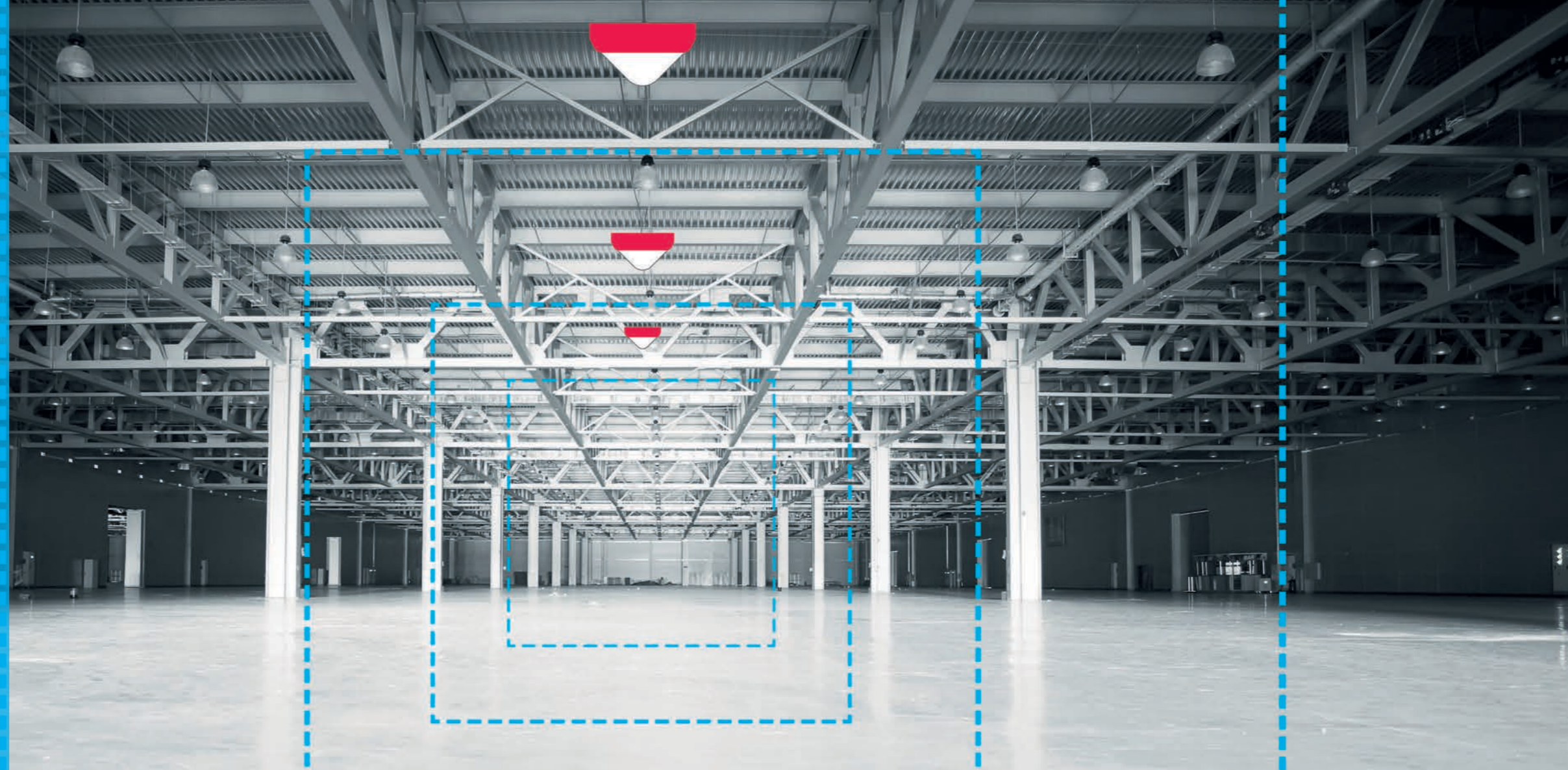

Setting the tone: our audible signaling devices.

The principle of electromagnetic sound generation is used on the EN-54-3-compliant signaling devices. As a result, they offer superior performance allowing a larger coverage area than devices based on piezo technology. To make the most out of this, our signaling devices also have an optimised acoustical design.



Fig. 13: Sounder in the PATROL series.

Simply brighter: our visual signaling devices.

Our EN-54-23-certified, category O visual signaling devices are equipped with XENON technology. The light pulses they emit convert the power supplied to them into an effective coverage area.

The ratio of the signaling range to power consumption is far better than on devices which are based on LED technology.

XENON technology has another advantage over the LED products available on the market: the shorter pulses and the higher intensity of the light emitted guarantee a better passive perception of the signal (when face is turned away from the signaling device).



Fig. 14: Flashing light in the PYRA series.

The best of both worlds: our visual-audible signaling devices.

These solutions combine the benefits of each device category into one high-performance unit. The signaling devices are supplied pre-wired and are therefore extremely easy to install.



Fig. 15: Combined visual-audible signaling devices of PATROL range

Superior performance and more: the benefits of our approved products.

- Certainty in the project planning phase.
- Guarantee of a compliant fire alarm system.
- Minimised liability risk.
- Cost reduction with short installation times.
- Cost reduction with low material requirements.
- For system integrators and manufacturers of fire alarm control panels: safety in terms of system requirements and compatibility.
- For building management companies: potentially lower insurance premiums.

The Pfannenberg group subsidiaries

Pfannenberg Europe GmbH

Werner-Witt-Straße 1

21035 Hamburg

Germany

Phone: +49 40 73412 156

Telefax: +49 40 73412 101

E-Mail: customercare@pfannenberg.com

Web: www.pfannenberg.com

Pfannenberg France, Rueil-Malmaison

Phone: +33 1 4708 4747

E-Mail: info@pfannenberg.fr

Pfannenberg United Kingdom, Rotherham

Phone: +44 1709 36 4844

E-Mail: info@pfannenberg.co.uk

Pfannenberg Italy, Fidenza (PR)

Phone: +39 0524 516 711

E-Mail: info@pfannenberg.it

Pfannenberg USA, N.Y.

Phone: +1 716 685 6866

E-Mail: info@pfannenbergusa.com

Pfannenberg Russia, St. Petersburg

Phone: +7 812 612 8106

E-Mail: info@pfannenberg.ru

Pfannenberg Singapore, Singapore

Phone: +65 6293 9040

E-Mail: info@pfannenberg.com.sg

Pfannenberg China, Suzhou

Phone: +86 512 6287 1078

E-Mail: info@pfannenberg.cn

Pfannenberg Brazil, Indaiatuba

Phone: +55 19 3935 7187

E-Mail: info@pfannenberg.com.br

Deliveries are made on the basis of the General Terms and Services of the ZVEI. Subject to technical amendments and misprints. This paper has been manufactured from chlorine-free bleached cellulose.



075000247

